

IN-LINE FANS TDM Series

The TDM series of axial fans have been specifically designed to be installed in **low pressure ducted systems**. Single phase motor 230V-50Hz, Class II, IPX4. Protected against overheating. Suitable to operate within temperatures up to 40°C.



Model TDM-100



TDM-300 Model

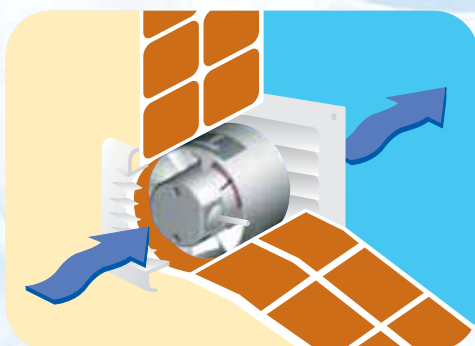

Models 100 and 200 can be installed within a wall to provide exhaust air operation or to exchange heat between adjacent rooms

■ Technical characteristics

Model	Speed (r.p.m.)	Maximum absorbed power (W)	Ø duct (mm)	Air volume at free discharge (m³/h)	Sound pressure level (dB(A))	Weight (kg)
TDM-100	2500	13	100	110	40	0,4
TDM-200	2600	25	125	200	44,5	0,6
TDM-300	2200	35	150	300	45	1,5

■ Dimensions (mm)

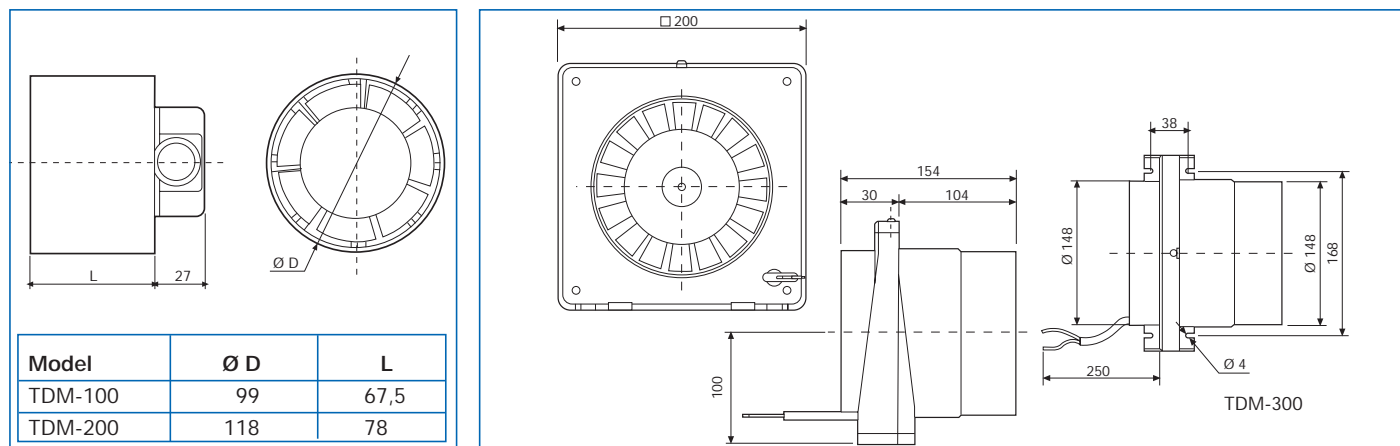

■ Performance curves

- Q = Air volume in, m³/hr and m³/s.
- Pe = Static pressure in mmWG and Pa.
- Dry air at 20°C and 760 mmHg.
- Air flow data in accordance with the following standards: UNE 100-212-89, BS 848, Part 1; AMCA 210-85 and ASHRAE 51-1985.

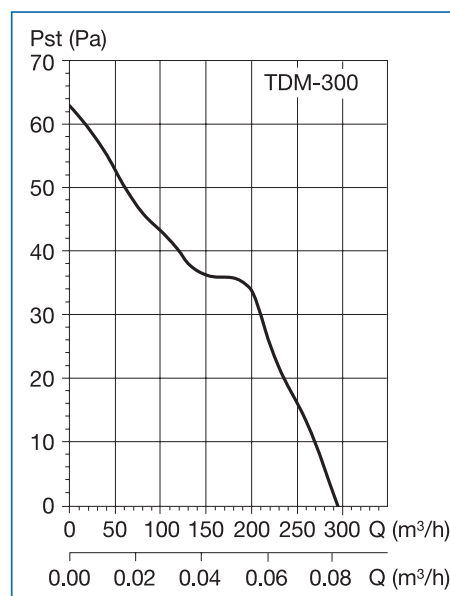
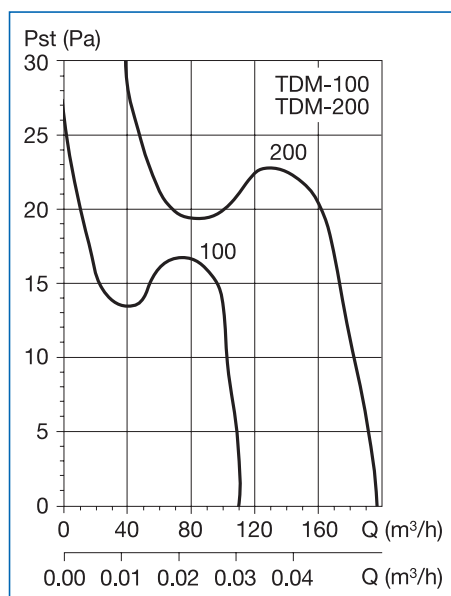

■ Accessories



GSA
Flexible aluminium ducting



GR-100
GRA
Exterior aluminium discharge guard



CX
Worm drive clips



PER-W
Plastic back draft shutters

Accessories	Discharge guard	Back draft shutters	Worm drive duct clamps	Aluminium flexible ducting
TDM-100	GR-100	PER-100W	CX-80/125	GSA-100
TDM-200	GRA-100	PER-125W	CX-125/215	GSA-125
TDM-300	GRA-150	PER-160W	CX-125/215	GSA-150