

VEN tac
G R O U P



Perforated face diffusers

VEN tac
air management

VEN tac
noise control

VEN tac
laboratories

Perforated Face Diffusers

CPD CPDE

Introduction

The Waterloo CPD range of diffusers have been designed for use in commercial applications and are particularly suited to projects with high air change rates and high cooling differentials.

CPD diffusers are suitable for installation in 300, 600 and 1200mm tile module systems and the range includes square and rectangular types.

The aluminium face plate may be pivoted down and removed to ease installation, commissioning and maintenance and is held closed by spring clips.

The diffusers are constructed from aluminium extruded frames and perforated face plates with plated steel, square, rectangular and circular connections suitable for top entry ducts.

Product Description

CPD2 2 way perforated face supply diffuser

CPD3 3 way perforated face supply diffuser

CPD4 4 way perforated face supply diffuser

CPDE Exhaust air perforated face diffuser

OBSS Opposed blade damper for square / rectangular connections

LD Louvre damper for circular connections

Features

- Integrate with 300, 600 and 1200mm tile sizes
- All aluminium face construction
- Pivoting, removable face plate
- Range of four sizes
- High air handling capacity
- Supply or exhaust diffusers visually compatible

Finishes

PPM9006 (RAL 9006 Matt Silver)

PPM9010 (RAL 9010 20% Gloss White)

PPG9010 (RAL 9010 Gloss White)

Other colours available on request

Free Area

54%

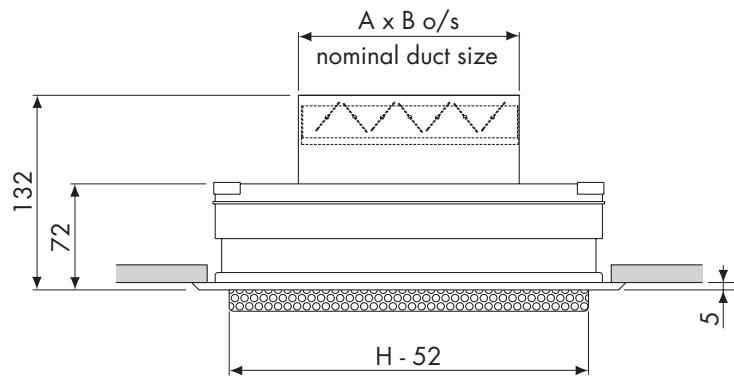
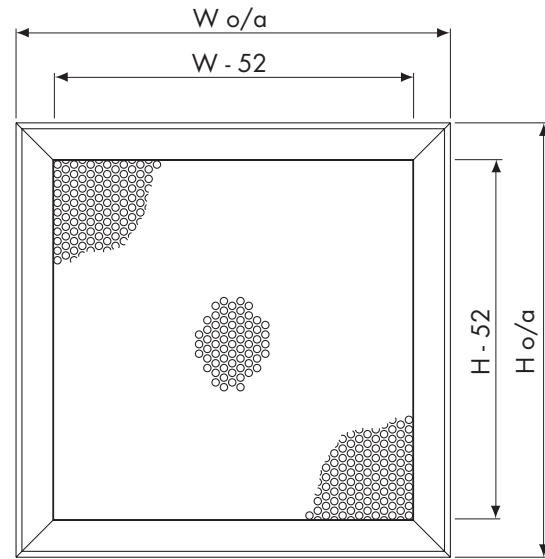

CPD/OBSS

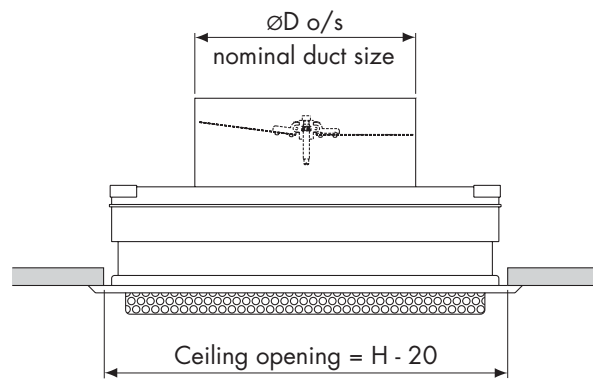

CPD/LD

Order Example

CPD/4/300x300/150 DIA/PPM9010/LD

Type	4
Pattern	300x300
Nominal Width	150
Nominal Height	DIA
Spigot Size	PPM9010
Finish	LD
Damper	

Type	Unit size	W x H	øD	A x B	Weight (kg)
CPD	300 x 300	295 x 295	147	147 x 147	2.0
CPD	600 x 600	595 x 595	297	297 x 297	3.4
CPD	600 x 300	595 x 295	—	297 x 147	2.8
CPD	1200 x 600	1195 x 595	—	597 x 297	6.5
CPDE	300 x 300	295 x 295	—	147 x 147	2.0
CPDE	600 x 600	595 x 595	—	447 x 447	3.4
CPDE	600 x 300	595 x 295	—	447 x 147	2.8
CPDE	1200 x 600	1195 x 595	—	597 x 297	6.5

Perforated Face Diffusers

CPD CPDE

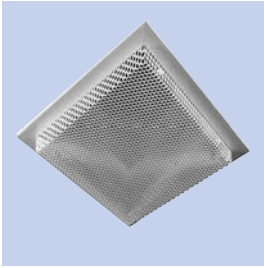

Selection Criteria

Ceiling height up to 2.8 m
 Radius of diffusion is based on terminal velocities of 0.75 m/s (minimum) and 0.10 m/s (maximum) to achieve mean room air velocities of 0.25 m/s and 0.10 m/s respectively.
 NR level is based on diffuser sound power level less 8dB room absorption.

Selection Example

CPD4/300x300/150

Air Flow Rate 88 l/s
 Throw 0.8 - 1.9m
 Static Pressure Loss 7 Pa
 Noise Level NR 33

Square Neck Supply Diffuser Corrections

CPD/300x300/150 x 150 as 150 \emptyset - 6dB Pa x 0.65
 CPD/600x600/300 x 300 as 300 \emptyset - 6dB Pa x 0.65

Performance Tables

CPD		4 way				3 way		
Sizes		300x300	600x600	600x300	1200x600	300x300	600x600	600x300
Spigot size		\emptyset 150	\emptyset 300	300x150	600x300	\emptyset 150	\emptyset 300	300x150
Air Flow Rate	m ³ /h	126	508	324	1296	126	508	324
	l/s	35	141	90	360	35	141	90
Throw Short Side Min.-Max. [m]		0.2-0.5	1.0-2.3	0.8-1.8	1.0-3.2	0.3-0.6	1.0-2.3	0.8-1.8
Throw Long Side Min.-Max. [m]		-	-	1.0-2.3	1.7-4.0	-	-	1.0-2.3
Noise Level [NR]		-	18	16	31	16	19	19
Static Pressure Loss [Pa]		1	3	4	18	2	3	4
Air Flow Rate	m ³ /h	191	763	486	1944	191	763	486
	l/s	53	212	135	540	53	212	135
Throw Short Side Min.-Max. [m]		0.4-0.9	1.5-3.6	1.3-3.1	1.8-4.0	0.5-1.1	1.5-3.6	1.3-3.1
Throw Long Side Min.-Max. [m]		-	-	1.9-4.4	2.6-5.0	-	-	1.9-4.4
Noise Level [NR]		22	27	28	42	24	28	26
Static Pressure Loss [Pa]		3	6	4	40	4	6	9
Air Flow Rate	m ³ /h	252	1015	648	2592	252	1015	648
	l/s	70	282	180	720	70	282	180
Throw Short Side Min.-Max. [m]		0.6-1.4	2.1-5.0	1.9-4.4	2.7-5.0	0.7-1.7	2.1-5.0	1.9-4.4
Throw Long Side Min.-Max. [m]		-	-	2.8-6.6	3.3-6.0	-	-	2.8-6.6
Noise Level [NR]		28	36	32	51	30	36	32
Static Pressure Loss [Pa]		5	10	14	70	7	11	17
Air Flow Rate	m ³ /h	317	1282	810	3240	317	1282	810
	l/s	88	356	225	900	88	356	225
Throw Short Side Min.-Max. [m]		0.8-1.9	2.7-6.2	2.5-5.8	3.3-5.3	1.0-2.3	2.7-6.2	2.5-5.8
Throw Long Side Min.-Max. [m]		-	-	3.8-8.9	4.0-6.3	-	-	3.8-8.9
Noise Level [NR]		33	44	40	61	35	44	40
Static Pressure Loss [Pa]		7	16	21	105	10	17	26
Air Flow Rate	m ³ /h	382	1526	972		382	1526	972
	l/s	106	424	270		106	424	270
Throw Short Side Min.-Max. [m]		1.1-2.6	3.3-7.7	2.9-6.9		1.3-3.0	3.3-7.7	2.9-6.9
Throw Long Side Min.-Max. [m]		-	-	4.7-11.0		-	-	4.7-11.0
Noise Level [NR]		38	53	45		39	53	45
Static Pressure Loss [Pa]		10	23	31		15	25	38
Air Flow Rate	m ³ /h	446				446		
	l/s	124				124		
Throw Short Side Min.-Max. [m]		1.4-3.3				1.6-3.8		
Throw Long Side Min.-Max. [m]		-				-		
Noise Level [NR]		41				42		
Static Pressure Loss [Pa]		14				20		
Air Flow Rate	m ³ /h	508				508		
	l/s	141				141		
Throw Short Side Min.-Max. [m]		1.7-4.0				2.0-4.6		
Throw Long Side Min.-Max. [m]		-				-		
Noise Level [NR]		44				45		
Static Pressure Loss [Pa]		19				27		

Perforated Face Diffusers

CPD CPDE

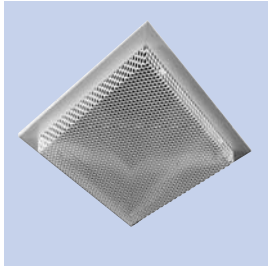

Selection Criteria

Ceiling height up to 2.8 m
 Radius of diffusion is based on terminal velocities of 0.75 m/s (minimum) and 0.10 m/s (maximum) to achieve mean room air velocities of 0.25 m/s and 0.10 m/s respectively.
 NR level is based on diffuser sound power level less 8dB room absorption.

Selection Example

CPD2/300x300/150

Air Flow Rate 70 l/s
 Throw 2.0 - 4.6m
 Static Pressure Loss 13 Pa
 Noise level NR 34

Square Neck Supply Diffuser Corrections

CPD/300x300/150 x 150 as 150 \varnothing - 6dB Pa x 0.65
 CPD/600x600/300 x 300 as 300 \varnothing - 6dB Pa x 0.65

Performance Tables

CPD		2 way			Exhaust			
Sizes		300x300	600x600	600x300	300x300	600x600	600x300	1200x600
Spigot size		\varnothing 150	\varnothing 300	300x150	150x150	450x450	450x150	600x300
Air Flow Rate	m ³ /h	126	508	324	162	486	1458	1296
	l/s	35	141	90	45	135	405	360
Throw Min.-Max. [m]		0.8-1.8	1.4-3.3	1.1-2.5				
Noise Level [NR]		20	23	21	-	-	-	-
Static Pressure Loss [Pa]		3	4	6	6	6	6	6
Air Flow Rate	m ³ /h	191	763	486	241	727	2185	1944
	l/s	53	212	135	67	202	607	540
Throw Min.-Max. [m]		1.3-3.1	2.3-5.4	2.5-5.8				
Noise Level [NR]		29	32	29	-	15	19	20
Static Pressure Loss [Pa]		8	9	12	10	10	10	10
Air Flow Rate	m ³ /h	252	1015	648	324	972	2916	2592
	l/s	70	282	180	90	270	810	720
Throw Min.-Max. [m]		2.0-4.6	3.2-7.6	3.8-9.0				
Noise Level [NR]		34	38	36	19	25	29	28
Static Pressure Loss [Pa]		13	16	22	14	14	14	14
Air Flow Rate	m ³ /h	317	1282	810	403	1213	3636	3240
	l/s	88	356	225	112	337	1010	900
Throw Min.-Max. [m]		2.7-6.3	4.1-9.7	5.4-12.7				
Noise Level [NR]		38	45	41	27	33	37	36
Static Pressure Loss [Pa]		21	25	34	20	20	20	20
Air Flow Rate	m ³ /h	382	1526	972	486	1458	4374	
	l/s	106	424	270	135	405	1215	
Throw Min.-Max. [m]		3.5-8.2	5.1-12.0	6.6-15.5				
Noise Level [NR]		41	53	45	33	39	43	
Static Pressure Loss [Pa]		30	27	50	40	40	40	
Air Flow Rate	m ³ /h	446			565	1699	5112	
	l/s	124			157	472	1420	
Throw Min.-Max. [m]		4.3-10.2						
Noise Level [NR]		44			38	44	48	
Static Pressure Loss [Pa]		40			50	50	50	
Air Flow Rate	m ³ /h	508						
	l/s	141						
Throw Min.-Max. [m]		5.0-12.2						
Noise Level [NR]		47						
Static Pressure Loss [Pa]		53						

Perforated Face Diffusers

CPD CPDE

Deflection Patterns

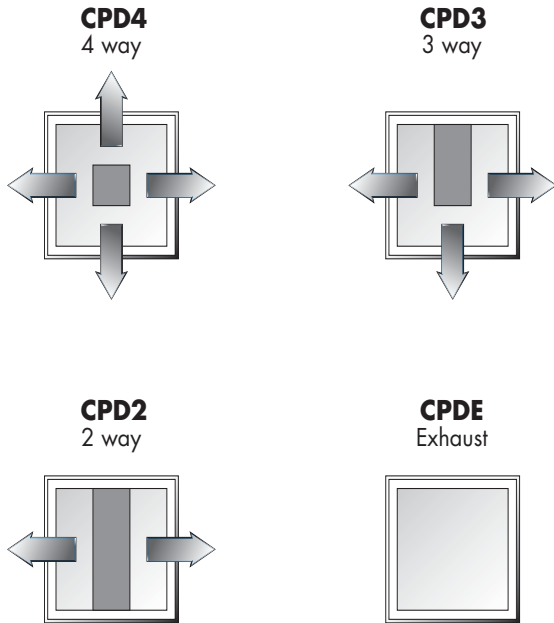

Nominal Size (mm)	Deflecting Pad Size		
	CPD4	CPD3	CPD2
300x300	150x150	195x150	240x150
600x600	200x200	370x200	540x200
600x300	300x150	420x150	540x150
1200x600	950x200	-	-

Installation

Drop rod (or tie wire) support method is recommended for concealed T and flush mounting options.

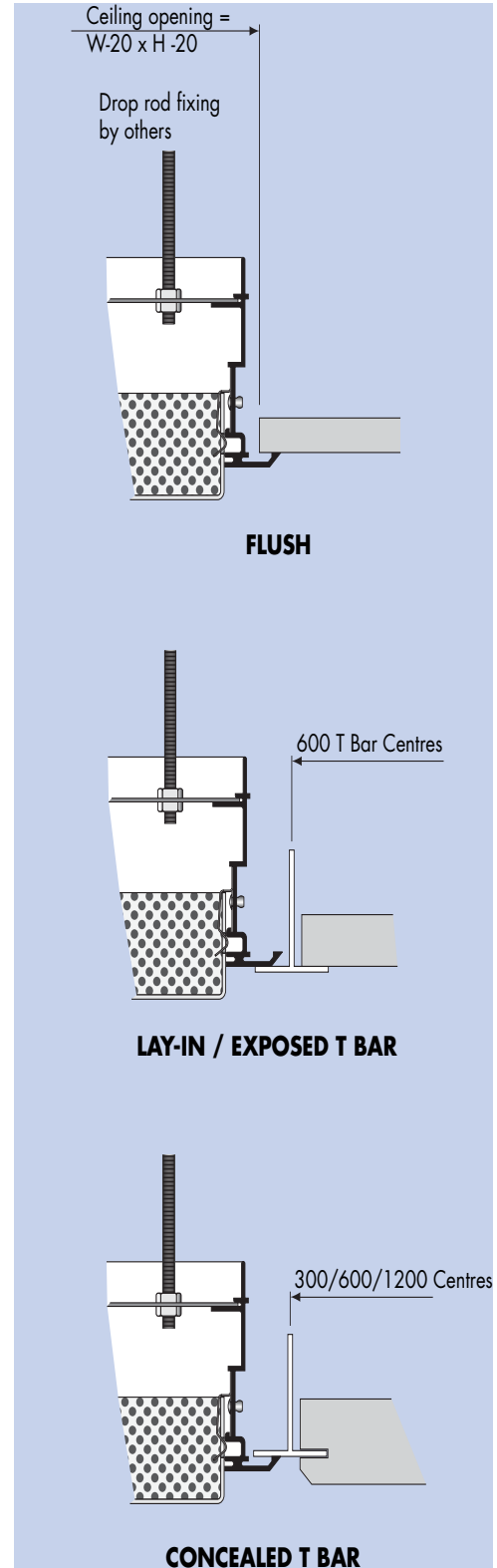
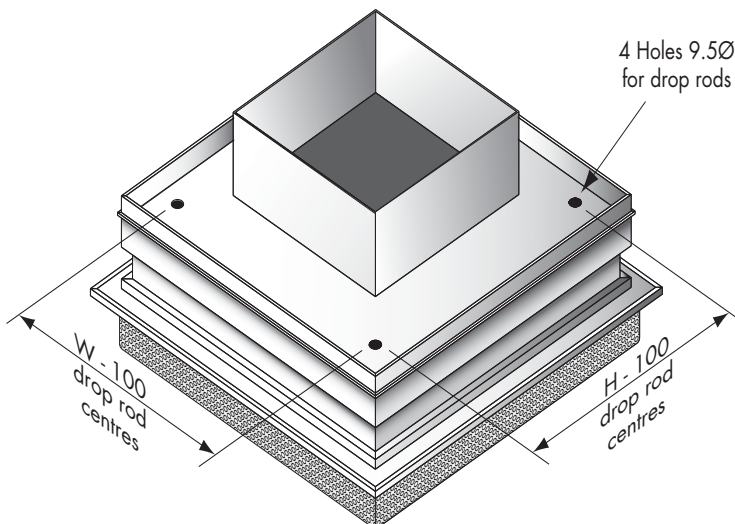

VEN tac

G R O U P

www.ventac.com

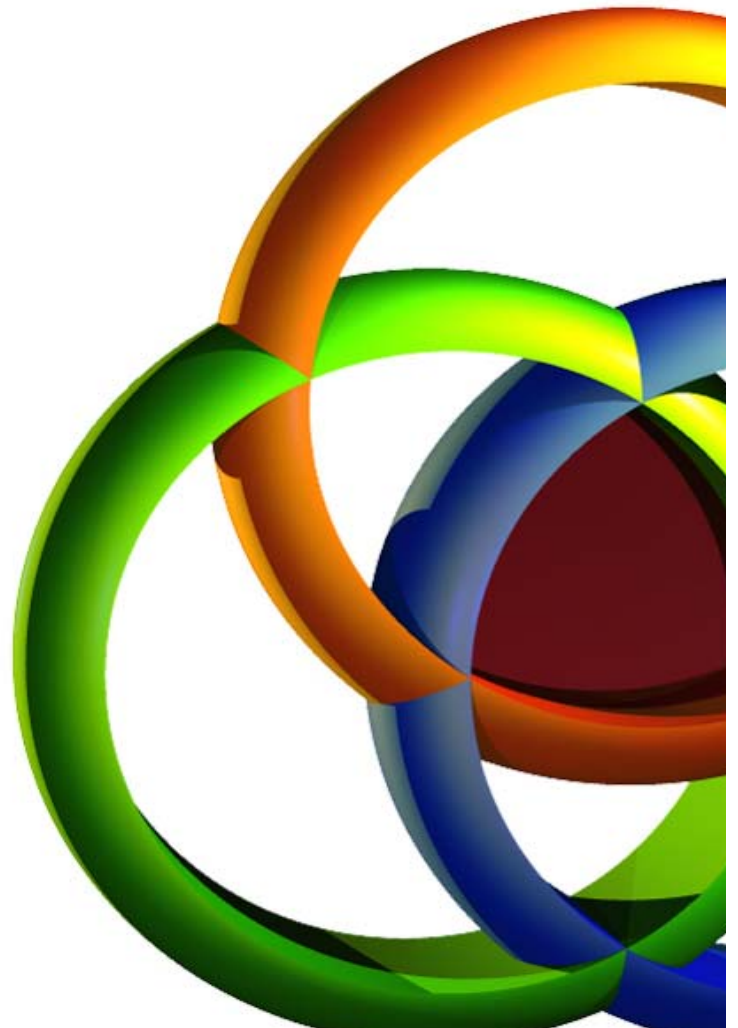

Fitzwilliam House, Blessington, Co. Wicklow, Ireland

t: 045 851500

f: 045 851501

e: sales@ventac.com

VEN tac
air management

VEN tac
noise control

VEN tac
laboratories