



HIGH EFFICIENCY HEAT RECOVERY UNIT

AKOR-HR

NEW



Heat Recovery unit with casing manufactured from expanded polypropylene.
 Outlet and inlet duct connectors Ø150.
 Very high efficiency counter cross flow heat exchanger with efficiency from 90 to 97%.
 High efficiency fans with DC motors.
 Condensate drain: 40 mm diameter PVC connection.
 Wall mounting support in galvanized steel sheet.

Additional Information

- Energy saving
- Very high thermal efficiency 90-97%
- Bypass operation mode
- Incorporates frost protection
- Filters to protect the heat exchanger
- Wireless 3 step control with timer supplied
- Easy to install
- Air tight construction
- Low energy consumption



A P P L I C A T I O N S



Attic or closet installation

Easy maintenance



Condensation drain plug



Outlet and Inlet connections



Filters



Heat exchanger

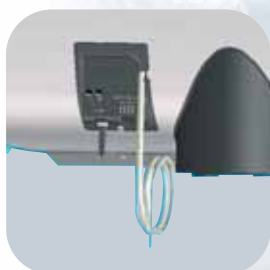

Fan speed control to adjust max. and min. airflow



Wireless control with timer on high speed from 10 to 30 min.

AKOR-HR

Heat Recovery

■ Technical characteristics

Model	Motor			Airflow (m ³ /h)	Running time for timer on high speed	Protection	Filter	Weight (Kg)
	Voltage (V)	Power (W)	Current (A)					
AKOR HR	230	14 / 44 / 160	0,09 / 0,29 / 0,89	75 / 150 / 275	10 to 30 mn	IP31	G3	25
AKOR-HR KIT	See the following chart							

■ Dimensions (mm)

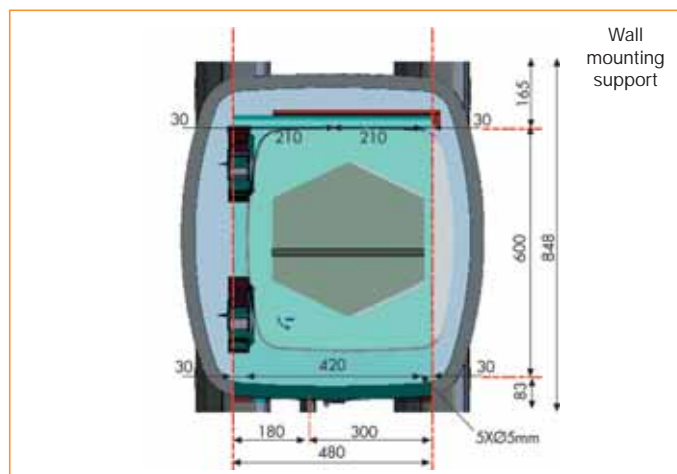
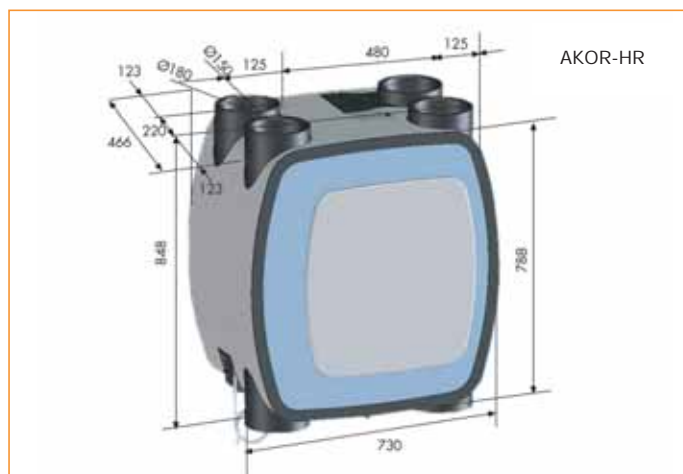

■ Thermal efficiency : 96,2% (in accordance with NEN 5138)

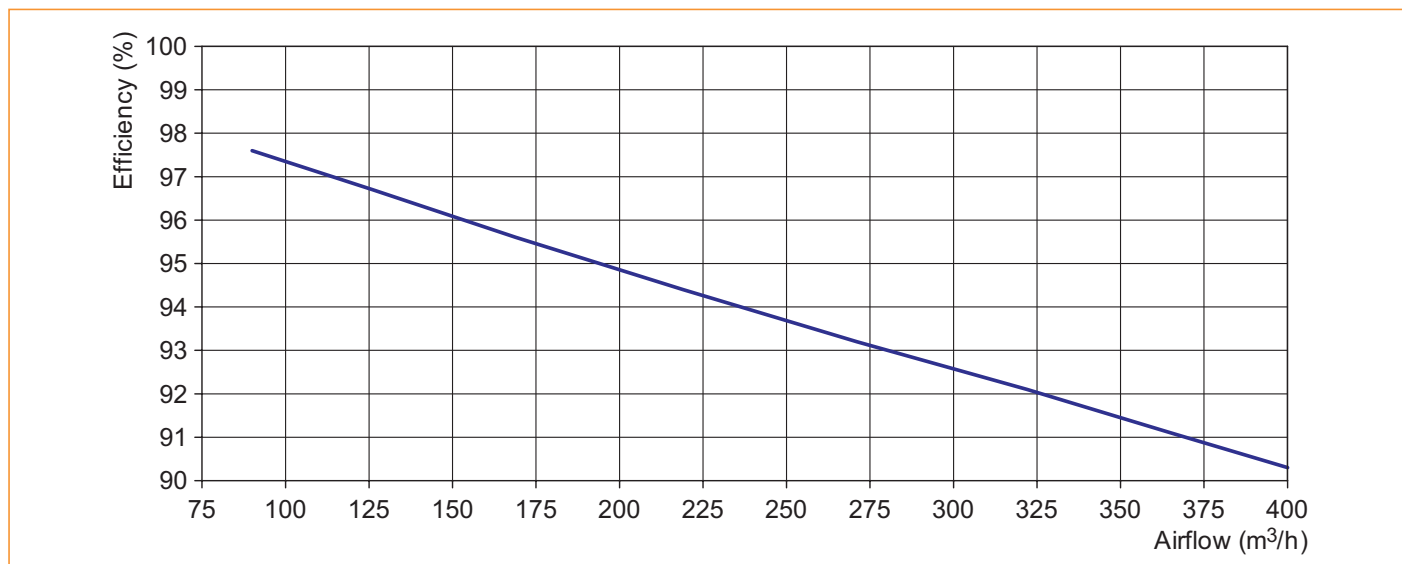

■ Example of installation with intake plenum AKOR with 10 connectors Ø 60 mm

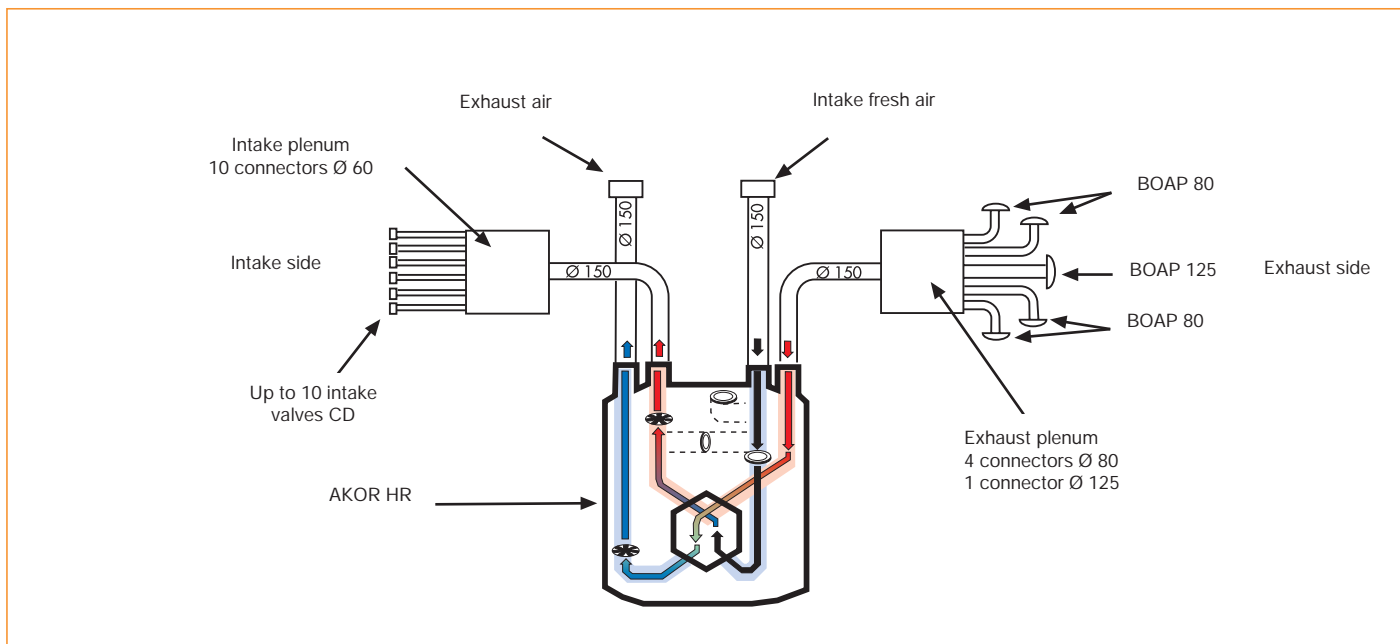

■ Example of installation with shunt duct system

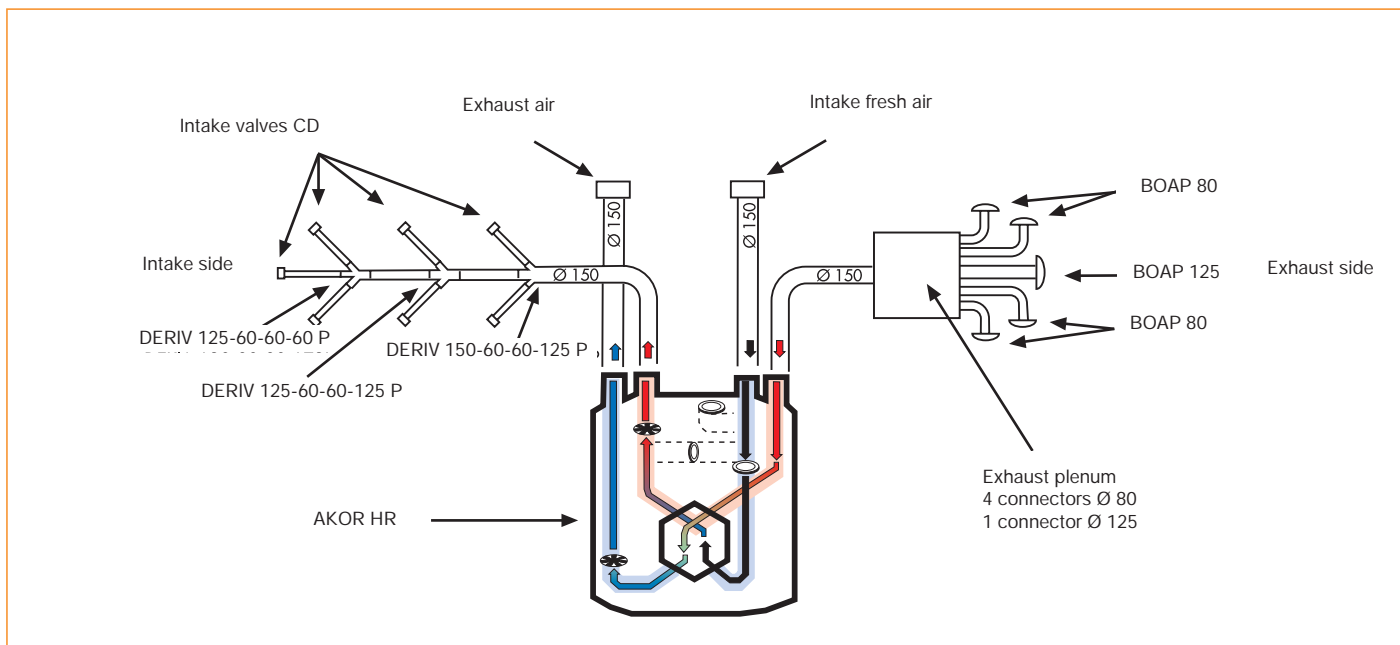

■ Operation

STANDARD OPERATION

- Heat exchanger valve open
- By-pass valve closed
- Frost protection valve closed

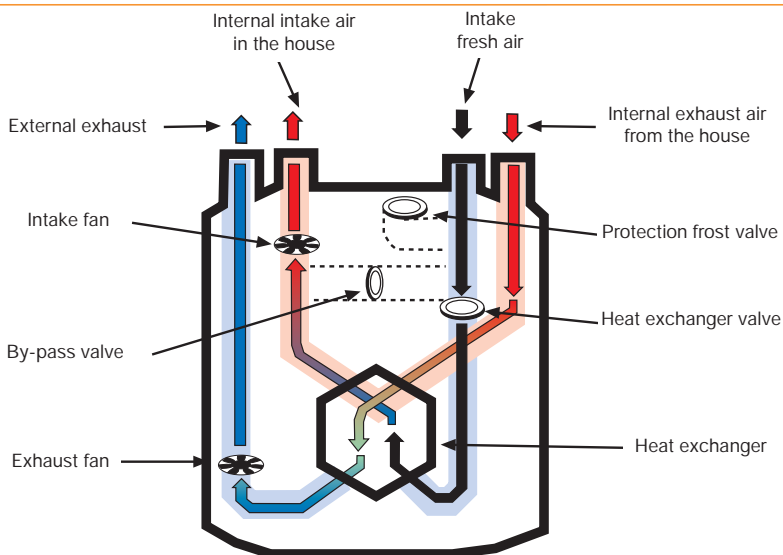

BY-PASS OPERATION

- Heat exchanger valve closed
- By-pass valve open
- Frost protection valve closed

Why?

Improve comfort: To cool the room without any energy consumption

How?

When the outside temperature is higher than the inside temperature, 100 % of the external fresh air goes through the by-pass without passing through the heat exchanger.

The By-pass is automatically controlled by a continuous temperature control.

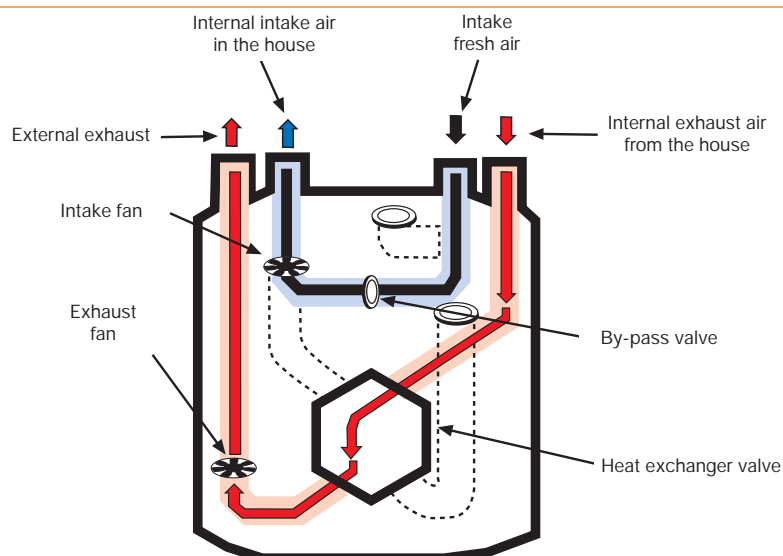

FROST PROTECTION OPERATION

- Heat exchanger valve open
- By-pass valve closed
- Frost protection valve open

Why?

to have the best result whatever the outside weather conditions.

How?

When the outside temperature is too low, the protection frost valve open to mix the AKOR warm surrounding air with external cold air. cold air. Intake fan will speed up.

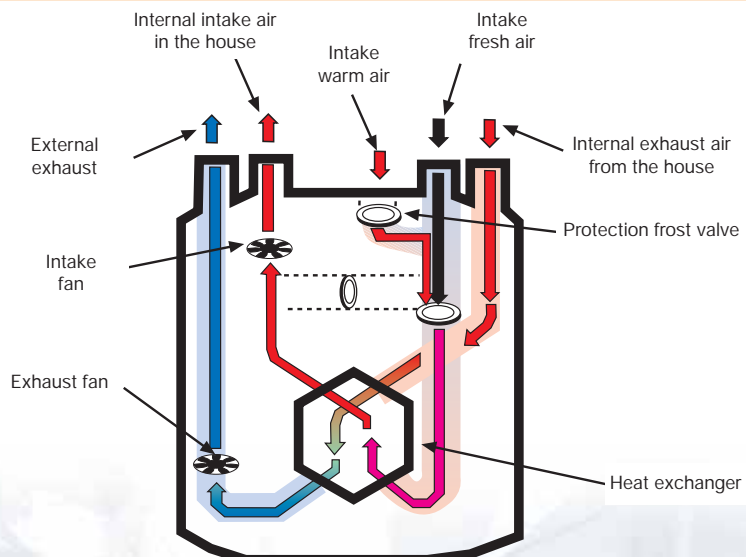

Accessories

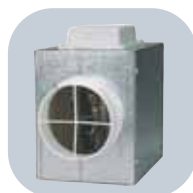

ABE defrosting unit

Prevents the formation of ice from the condensation on the interchanger plates in the air extract. Made from galvanized steel plate and supplied with polyethylene clips. It has a heat resistance of 500W and control thermostats.

Model	Diameter (mm)
ABE - 150/0.5M	150



ABE heating unit

Allows the temperature of the blown air to be increased. It has a 500W power heating element and control thermostats.

Model	Diameter (mm)
ABE-150/0.5M	150



CD intake grill

Designed to introduce air into individual houses. It can be installed on a wall, ceiling or on straight or inclined ceiling tiles. Diameter 60 mm

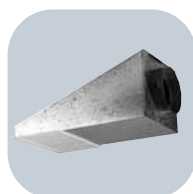

Air inlet for false ceiling mounting

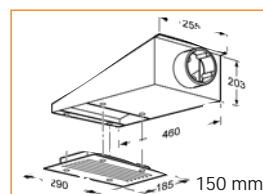

BOAP/BOAC plastic extract grill

Model	Diameter (mm)
BOAP 80	80
BOAC 80	80
BOAP 125	125
BOAC 125	125

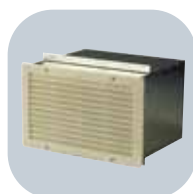

Air inlet, wall-mounted

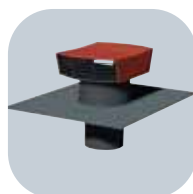
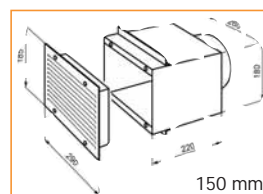

CT-150 extract roof cowl

Model	Diameter (mm)
CT 150 P TILE	150
CT 150 P SLATE	150



GP ISO insulated flexible duct

Model	Diameter (mm)
GP ISO 60	60
GP ISO 80	80
GP ISO 125	125
GP ISO 150	150



MRT Plastic connection for connecting 2 ducts from the same diameter

Model	Diameter (mm)
MRT 60 P	60
MRT 80 P	80
MRT 125 P	125
MRT 150 P	150



Sound attenuator

LA 80
LA 125



Duct fittings

Model	Diameters			
	A (mm)	B (mm)	C (mm)	D (mm)
DERIV 80-80 P	80	80	80	
DERIV 125-60-60-125 P	125	60	60	125
DERIV 125-60-60-60 P	125	60	60	60
DERIV 150-125-125 P	150	125	125	
DERIV 150-60-60-125 P	150	60	60	125

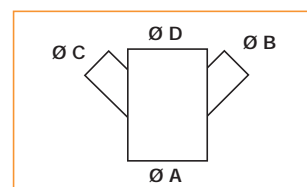

AKOR Plenum

10 inlet spigots in 60 mm diameter. Outlet spigot in 150 mm diameter. 5 covers.



AKOR switch (Extract/Input)

2 extract positions with stop
2 input positions with stop

