



WALL OR WINDOW EXTRACT FANS

# HV-STYLVENT Series



Complete range of axial flow fans for wall or window mounting applications. All the fans are supplied with tough ABS plastic grilles, shutter and single phase 230V- 50Hz motor. All the fans are class II insulation and IPX4 rated. The HV-STYLVENT series comprises of 3 diameters: 150, 230 and 300 mm, including several operating options, making them ideally suited for a wide range of general residential, commercial and industrial exhaust or supply ventilation applications.

HV-STYLVENT



Wall or window extract fans

Shutter



To prevent air entry and limit heat leakage when the extractor is not operating

Reversible

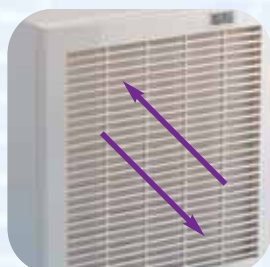

Extract or supply operation

Natural ventilation position

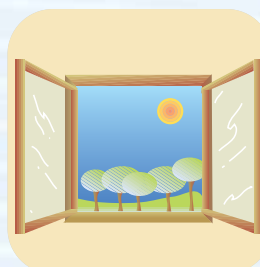

Shutter open, fan off



Elegant design harmonising with any environment



## HV- AE versions



### Standard range

- Single-phase motor 230V50Hz with thermal overload protection
- Single speed operation
- Class II insulation
- Model 230 and 300 are reversible with CR-150 control accessory
- Automatic, thermally actuated shutter

- HV-150 AE: 2 Positions:      OFF - Fan OFF, shutter closed  
    ON - fan ON, working as air extract with shutter open
- HV-230 AE: 3 positions (with CR-150 control accessory)  
 HV-300 AE      OFF - Fan OFF/Shutter closed  
                                  ON - Fan ON/shutter open  
                                  ←→ Fan working as air extract/supplying air

REB-1R control: Speed controller including a switch to reverse the airflow direction

## HV-M versions



### Manually operated models via integral pull cord

- Single speed (HV-150M) or 2-speed (HV-230M and 300M) operation
- Model 230 and 300 are reversible
- Natural ventilation position (shutter open, fan off - except HV-150M)
- Neon lights indicating the mode of operation

- HV-150 M: 2 Positions:      Fan OFF, shutter closed  
    Fan ON, working as air extract with shutter open

- HV-230 M: 5 Positions:  
 HV-300 M      1-Fan stopped and shutter closed  
                                  2-Fan on high speed working as air extract with shutter open  
                                  3-Fan on low speed working as air extract with shutter open  
                                  4-Fan stopped and shutter open  
                                  5-Fan in reverse high speed supplying air in the room with shutter open

## HV-A versions



### Automatic models operated via control unit CR

- Single speed (HV-150A) or 2-speed (HV-230A and 300A) operation
- Model 230 and 300 are reversible
- Natural ventilation position (shutter open, fan off)
- Neon lights indicating the mode of operation

- HV-150 A: 3 Positions:      - Fan OFF, shutter closed  
    - Fan OFF, shutter open  
    - Fan ON, working as air extract  
 To operate all these functions use the accessory CR-150

- HV-230 A: 5 Positions:  
 HV-300 A      1-Fan stopped and shutter closed  
                                  2-Fan on high speed working as air extract with shutter open  
                                  3-Fan on low speed working as air extract with shutter open  
                                  4-Fan stopped and shutter open  
                                  5-Fan in reverse high speed supplying air in the room with shutter open  
 To operate all these functions use the accessory CR-300

### HV-RC versions



#### Radio control range

- Two speed operation
- Natural ventilation position
- All models are reversible
- Automatic, thermally actuated shutter
- Neon light mode of operation indication

- HV-230 RC: 6 Positions:  
 HV-300 RC: 6 Positions:
- 1-Fan stopped and shutter open
  - 2-Fan stopped and shutter closed
  - 3-Fan on high speed working as air extract with shutter open
  - 4-Fan on reverse high speed supplying air in the room with shutter open
  - 5-Fan on low speed working as air extract with shutter open
  - 6-Fan in reverse low speed supplying air in the room with shutter open

### HVE versions



#### Flush mounted version

- HVE-230 AE: 3 same positions that HV-230 AE  
 HVE-230 A: 5 same positions that HV-230 A  
 HVE-230 RC: 6 same positions that HV-230 RC

## ■ STYLVENT Product Summary – Operational Specifications

Model	Flush mounted	Single speed	Two speed	Reversible	Natural ventilation	Pull cord	Electrical accessories			Radio control
							REB-1R	CR-150	CR-300	
HV-150 M		•				•				
HV-230 M			•	•	•	•				
HV-300 M			•	•	•	•				
HV-150 AE		•						•		
HV-230 AE		•		•			•			
HV-300 AE		•		•			•			
HV-150 A		•			•			•		
HV-230 A			•	•	•					•
HV-300 A			•	•	•					•
HV-230 RC			•	•	•					•
HV-300 RC			•	•	•					•
HVE-230 AE	•	•		•			•			
HVE-230 A	•		•	•	•				•	
HVE-230 RC	•		•	•	•					•

Maximum ambient operating temperature for all models: 45°C.

One remote control can operate several HV.RC. In that case, the fans must be installed with a minimum distance of 1,5 meters between fans.

## Technical characteristics

Model	Speed (r.p.m.)	Maximum absorbed power (W)	Maximum absorbed current (A)	Airflow rate (m <sup>3</sup> /h)			N.P.S* at 3 m (dB(A))		Weight (kg)
				Extraction		Intake	High speed	Low speed	
				High speed	Low speed				
HV-150 AE	1800	32	0,19	225	-	-	39	-	2,0
HV-150 M	1800	32	0,19	225	-	-	39	-	2,0
HV-150 A	1800	32	0,19	225	-	-	39	-	2,0
HV-230 AE	1250	34	0,15	600	-	330	43	-	3,5
HVE-230 AE	1250	34	0,15	600	-	330	43	-	3,5
HV-230 M	1250	34	0,15	600	450	330	43	37	3,5
HV-230 A	1250	34	0,15	600	450	330	43	37	3,5
HVE-230 A	1250	34	0,15	600	450	330	43	37	3,5
HV-230 RC	1250	34	0,15	600	450	330	43	37	3,5
HVE-230 RC	1250	34	0,15	600	450	330	43	37	3,5
HV-300 AE	1150	68	0,30	1100	-	700	46	-	5,1
HV-300 M	1150	68	0,30	1100	750	700	46	38	5,1
HV-300 A	1150	68	0,30	1100	750	700	46	38	5,1
HV-300 RC	1150	68	0,30	1100	750	700	46	38	5,1

\*PSL: Sound Pressure Level measured at 3 m.

## Dimensions (mm)

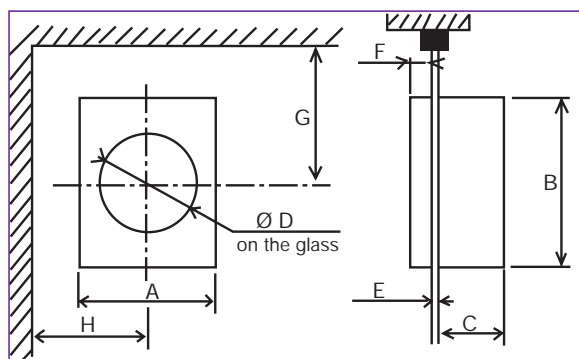

Model	A	B	C	Ø D		E		F	G	H
				Min.	Max.	Min.	Max.			
HV-150	230	251	109	187	190	3	25	22	160	150
HV-230	300	325	142	259	262	3	25	22	200	185
HV-300	368	403	150	327	330	3	25	22	230	220

### Dimensions of the HVE "flush mounted" version

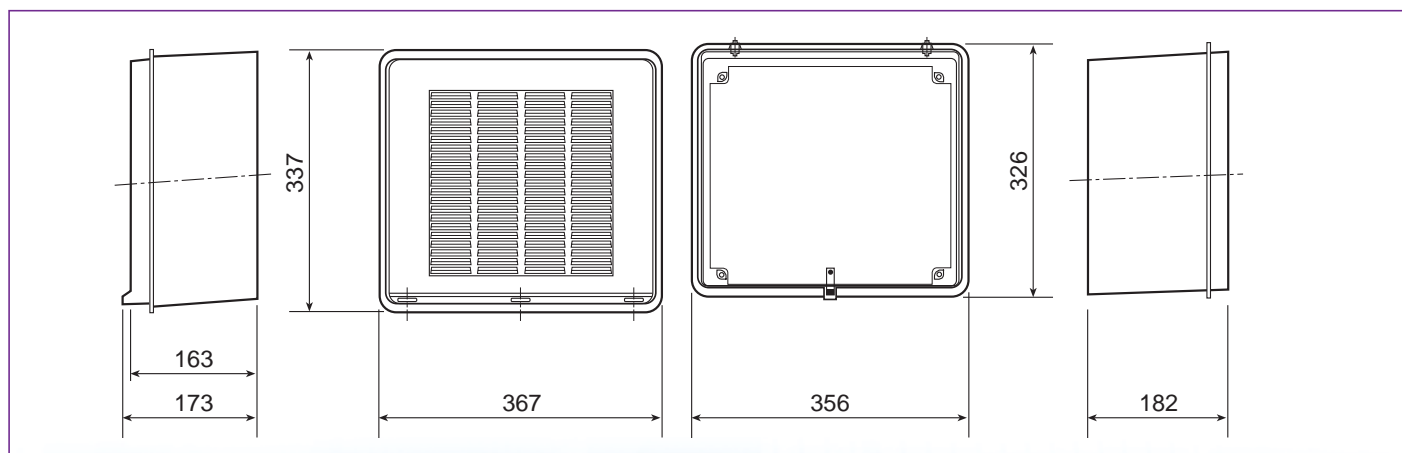

## ■ Installation in glass or panels from 3 to 25 mm thickness

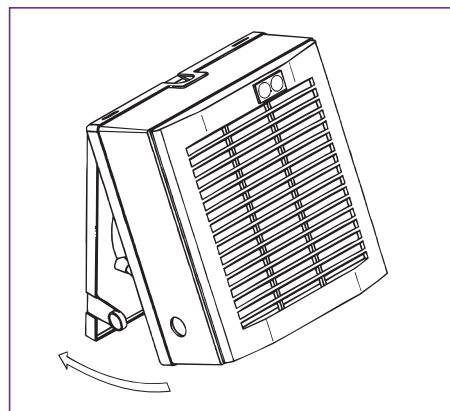
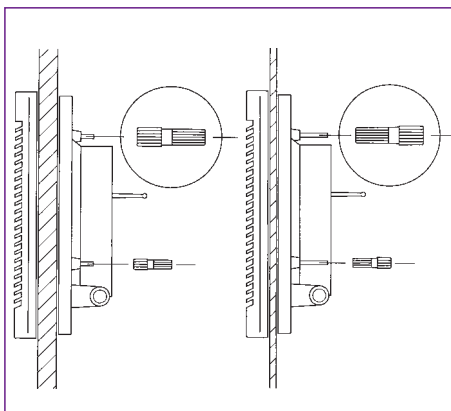
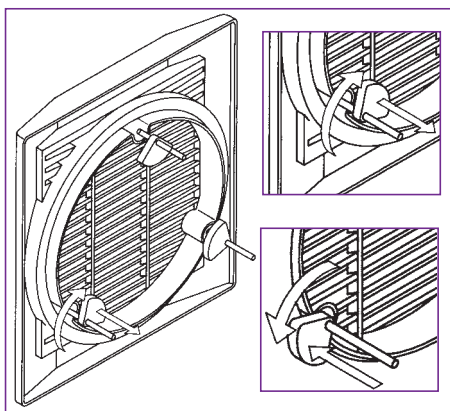

### Fast and simple three stage installation

The STYLVENT series of fans are designed for speed of installation in three easy stages.

#### Stage 1 - External grille

Once in position, the external grille is held by three rubber plugs which allow the installer to assemble the interior section of the fan.

#### Stage 2 - Support frame

To enable easy mounting of the support frame, the holes are tapered and the fixing screws can be located depending on the glass/panel thickness:

3 mm < thickness < 10 mm ←

10 mm < thickness < 25 mm ←

#### Stage 3 - Internal grille

Finally, place the lugs on the top of the support frame into the rectangular slots on the front grille it into position.

## For a wall mounted installation it is necessary to use the extended threaded rod set (see Installation Accessories) Installation on walls from 25 to 300 mm thick

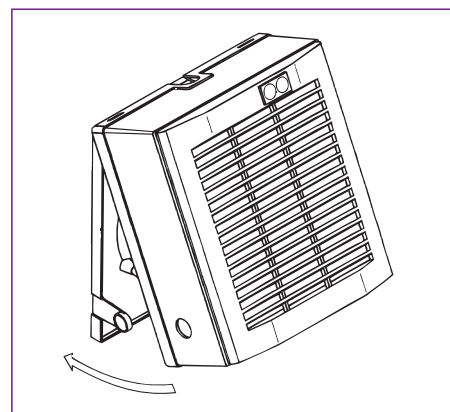
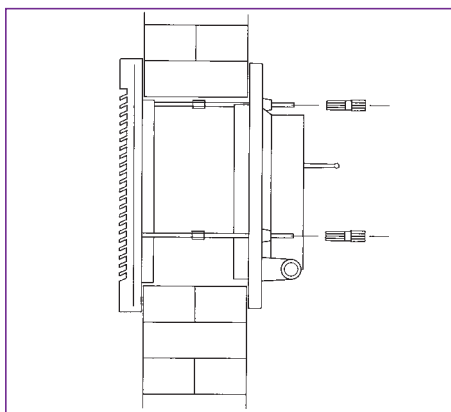
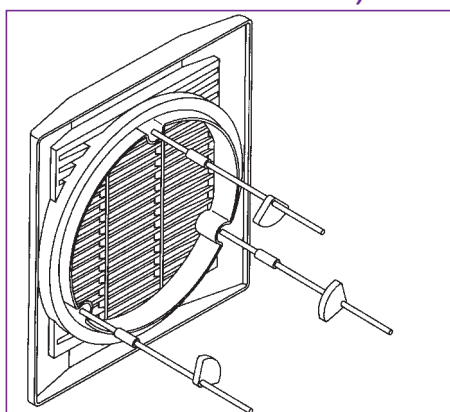

Before installation, rods must be cut to 5mm less than the thickness of the wall. Cut a hole in the wall in accordance with the dimensions shown in the table (to right).

Ensure that internal wall mounting surface is as smooth as possible.

On the interior of the wall, mark the fixing hole positions using the support plate as a template.

Fit the threaded rods to the external guard using

the threaded sleeves. Place the external grille into position and hold in place with the rubber plugs.

Then, the installation follows the same stages as in the glass installation except for the support frame installation, which has to be fixed using 2 or 4 screws (HV-150, HV-230 and HV-300 models respectively).

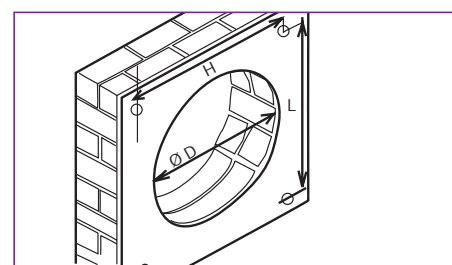

Model	Ø D		H*	L*
	Min.	Max.		
HV-150	187	190	117	121
HV-230	259	262	152	165
HV-300	327	330	322,5	357,3

\* There are only two diagonal fixing holes for model HV-150.

## Performance curves

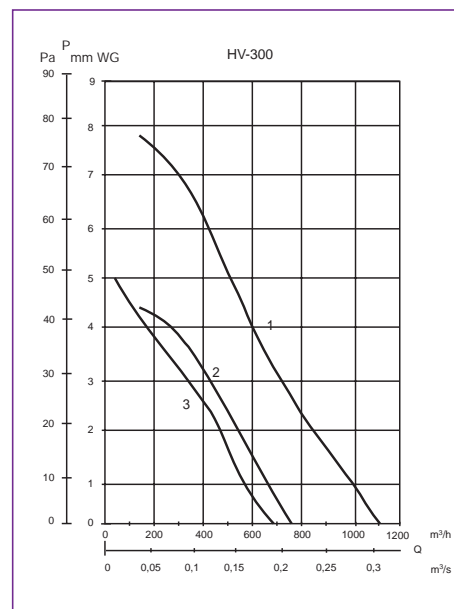
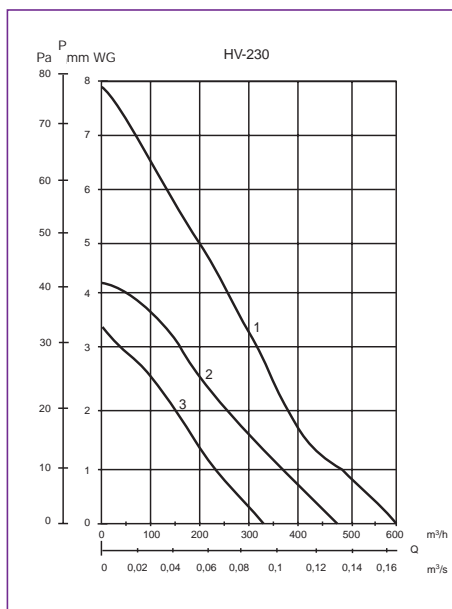
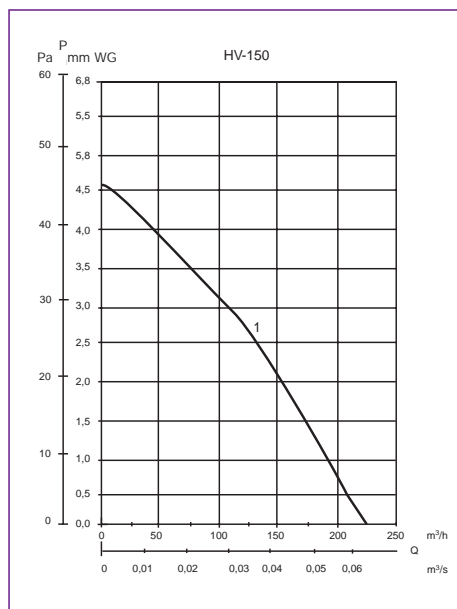

- 1- Extraction on high speed.
- 2- Extraction on low speed.
- 3- Air intake

Q = Airflow in m<sup>3</sup>/h and m<sup>3</sup>/s  
 P = Static pressure in mmWG and Pa  
 Standard dry air at 20°C and 760 mm Hg  
 Tests carried out according to UNE 100-212-89 and BS 848 part 1

## Acoustic characteristics

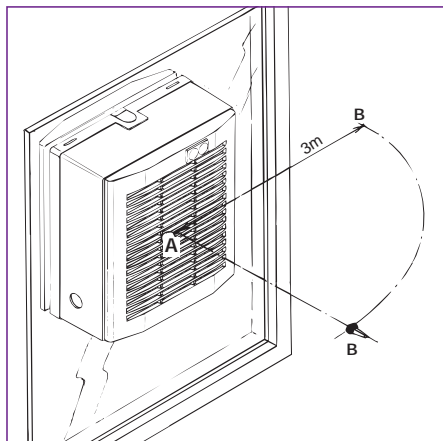

The values shown for the Sound Pressure Levels in the technical characteristics table are measured in dB(A) at 3 m (position B) as shown in the diagram. The table below shows the necessary corrections to calculate the Sound Power Level Spectrum -SWL, at the inlet (point A) and outlet at high speed (in Hz).

	Inlet						
Lw(A)	125	250	500	1000	2000	4000	8000
HV-150	+5,5	+12	+16	+14	+13	+7	+4,5
HV-230	+9	+10,5	+13,5	+16,5	+13,5	+5	+0,5
HV-300	+7	+8,5	+14	+16,5	+13	+6	-0,5

	Outlet						
Lw(A)	125	250	500	1000	2000	4000	8000
HV-150	+6,5	+10,5	+18,5	+16,5	+14,5	+8	+4,5
HV-230	+6,5	+11	+16,5	+18	+15	+6,5	+0,5
HV-300	+5,5	+11,5	+17	+19	+15	+6,5	0

## Electrical accessories



### CR-150

Control unit for HV-150 A  
Fitted with:

- On/off switch for fan operation. (☀ - ☁)
- On/Off switch for shutter operation
- One single CR-150 unit can operate up to 5 HV-150 fans.



### CR-300

Control unit for HV-230 A, HV-300 A and HVE-230 A  
Fitted with:

- A selector for the different modes of fan operation (0, ●, ●, ●, ☀)
- A reversing switch to change the airflow direction (☐, ☐)
- One single CR-300 unit can operate up to 5 HV-230 or 300 fans.



### REB-1R

Speed controller including a switch to reverse the airflow direction. Only to be used with models HV-230 AE, HV-300 AE and HVE-230 AE Max 1A.



### Connection cable

A (7) core wire cable for the connection of models HV-230 A and HV-300 A to the remote control unit CR-300. (Supplied on 10m rolls as standard)

Model	Electrical supply		IP protection	Power (VA)	Maximum current (A)	Class	Temperature	Dimensions (mm)		
	Frequency (Hz)	Voltage (V)						L	A	H
REB-1R	50	220-240	IP-40	400	1	II (☐)	0-40°C	160	58	88
Control unit CR-150								88	47	88
Control Unit CR-300								158	57	88

## Installation accessories

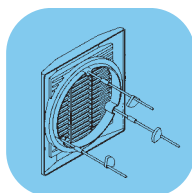

### Threaded Rod set

Threaded rods and sleeves for use when installing the HV fans on walls from 25 mm up to 300 mm thick