

CENTRIFUGAL IN-LINE FANS

VENT Series



VENT-100 to VENT-315



VENT-355 and VENT-400



Range of in-line duct centrifugal fans, manufactured from high grade corrosion resistant pressed galvanised steel and supplied as standard with a pre-wired wiring junction box and a robust mounting foot. All model include an enclosed type, single-phase external rotor motor with factory matched backward curved non-stalling impeller.

(1)Models 355 and 400 are manufactured in sheet steel protected against corrosion by cataforesis primer and black polyester paint finish.

**Motors**

100 – 315 models: Motors are IP44, class F insulation with ball bearings and safety thermal overload protection.

355 and 400 models: Motors are IP54, class F, with ball bearings and safety thermal overload protection.

Electrical supply:

Single phase 230V 50/60Hz.

Three phase 230/400V 50Hz (models 355 and 400). (See characteristics chart).

All models are speed controllable.

**Additional Information**

"L" version: High performance models.

"B" Version: Standard performance models for lower noise level requirements.

Impellers from 100 to 160 models are manufactured from injection moulded plastic.

A P P L I C A T I O N S

**Mounting foot**



Supplied with unit as standard



Warehouses

Workshops



Commercial premises

Offices



Cafes, bars and small restaurants

Commercial and industrial kitchens

## ■ Technical characteristics

Before installation check that the product electrical characteristics listed on the data plate label (Voltage, power, frequency etc) match those of the intended electrical supply.

Model	Voltage V/Hz	Speed (rpm)	Maximum absorbed power (W)	Maximum absorbed current (A)	Maximum airflow (m <sup>3</sup> /h)	Sound pressure level (dB(A))	Maximum ambient temperature (°C)	Weight (kg)
VENT-100B	230 - 50	2100	48	0,22	235	38	40	3
VENT-100L	230 - 50	2500	75	0,33	290	47	60	3
VENT-125B	230 - 50	1900	44	0,21	280	39	40	3
VENT-125L	230 - 50	2450	80	0,35	410	47	60	3
VENT-150B	230 - 50	2100	70	0,30	560	46	60	5
VENT-150L	230 - 50	2700	120	0,53	700	50	60	5
VENT-160B	230 - 50	2200	70	0,30	600	45	60	5
VENT-160L	230 - 50	2750	130	0,55	760	51	60	5
VENT-200B	230 - 50	2250	125	0,50	830	47	60	5
VENT-200L	230 - 50	2600	170	0,72	1000	52	60	5
VENT-250B	230 - 50	2300	130	0,55	935	49	60	6
VENT-250L	230 - 50	2750	180	0,80	1100	54	60	6
VENT-315B	230 - 50	2300	235	1,00	1440	52	50	8
VENT-315L	230 - 50	2700	350	1,50	1890	55	50	8
VENT-355L	230 - 50	1350	280	1,20	2650	60	70	17
VENT-400L	230 - 50	1250	400	1,60	3380	61	50	22

VENT-355L-T	230/400 - 50	1375	290	1,4/0,8	2650	60	70	17
VENT-400L-T	230/400 - 50	1360	450	1,9/1,1	3380	61	50	22

## ■ Dimensions (mm)

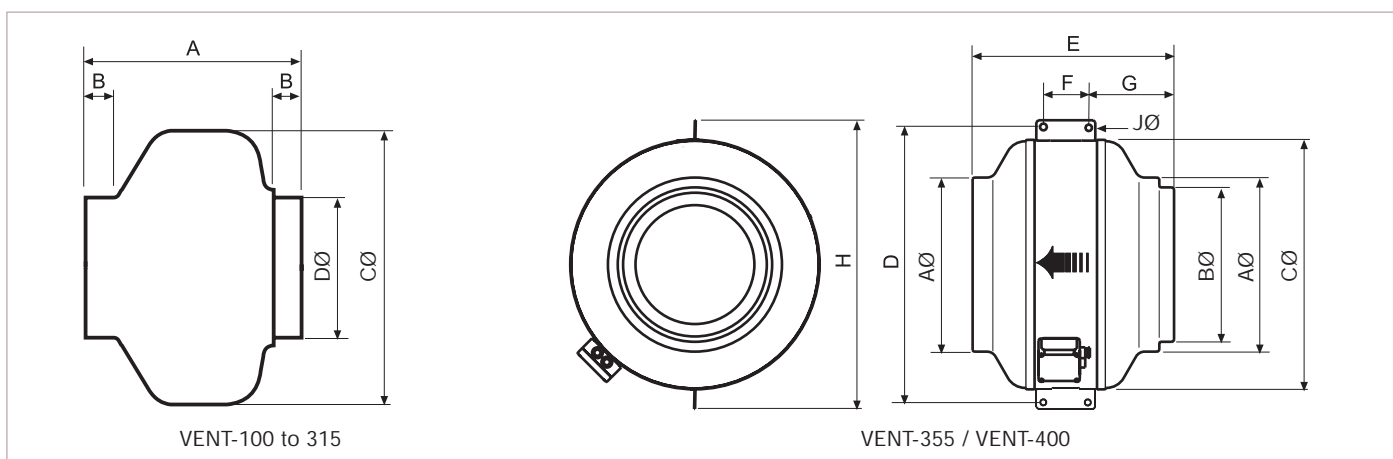

Type	A	B	C	D	E	F	G	H	J
VENT-100	194	23	243	98					
VENT-125	195	27	243	123					
VENT-150	214	24	333	147					
VENT-160	222	28	333	157					
VENT-200	223	25	333	198					
VENT-250	206	27	333	248					
VENT-315	230	25	401	312					
VENT-355	354	314	508	583	410	100	170	587	10,5
VENT-400	399	354	568	623	441	100	185	647	10,5

## Acoustic characteristics

Sound power level spectrums (LwA) at the maximum airflow (0Pa).

Model	LwA	63	125	250	500	1000	2000	4000	8000	TOT
100L	Inlet	44	53	63	60	67	61	52	41	70
	Disch.	42	48	67	61	63	61	55	44	70
	Rad.	42	44	53	51	46	45	40	33	56
100B	Inlet	37	43	54	49	59	54	48	39	61
	Disch.	38	42	56	48	53	53	49	38	60
	Rad.	36	33	32	36	40	38	34	26	45
125L	Inlet	38	47	59	67	65	62	56	44	70
	Disch.	38	45	61	64	63	63	56	46	69
	Rad.	37	43	45	51	47	45	42	33	54
125B	Inlet	33	43	55	57	57	55	51	41	62
	Disch.	34	41	57	53	55	56	52	41	62
	Rad.	34	36	35	38	41	39	37	28	46
150L	Inlet	40	45	63	73	69	64	61	46	75
	Disch.	40	45	63	66	67	64	61	47	72
	Rad.	40	37	46	59	51	50	43	30	60
150B	Inlet	36	44	58	70	64	60	56	40	71
	Disch.	36	43	55	62	62	59	56	40	67
	Rad.	36	38	40	53	46	45	41	29	55
160L	Inlet	39	45	63	74	70	67	63	48	77
	Disch.	43	45	61	67	68	65	62	49	72
	Rad.	43	36	44	60	52	51	45	32	61
160B	Inlet	35	41	56	69	63	60	56	42	71
	Disch.	35	42	54	63	61	59	57	42	67
	Rad.	35	37	37	52	45	45	42	29	54

Model	LwA	63	125	250	500	1000	2000	4000	8000	TOT
200L	Inlet	42	52	63	70	69	68	66	60	75
	Disch.	43	51	63	70	69	69	68	59	75
	Rad.	43	48	40	51	53	52	49	39	58
200B	Inlet	41	53	60	67	66	64	63	52	72
	Disch.	42	51	61	65	66	66	65	53	72
	Rad.	42	42	34	46	48	53	46	37	56
250L	Inlet	43	57	67	71	72	70	70	60	78
	Disch.	42	53	67	73	75	75	72	62	80
	Rad.	36	52	37	53	53	51	50	38	59
250B	Inlet	42	53	62	68	69	66	66	57	74
	Disch.	39	48	62	70	70	69	67	59	76
	Rad.	38	43	36	52	48	50	48	42	56
315L	Inlet	45	58	70	74	75	76	71	66	81
	Disch.	57	58	72	76	77	77	72	68	83
	Rad.	51	54	49	56	61	59	56	48	65
315B	Inlet	44	59	68	70	71	70	67	60	77
	Disch.	44	51	71	72	75	74	69	64	80
	Rad.	43	43	47	50	52	55	53	43	59
355L	Inlet	40	57	68	71	71	67	59	48	76
	Disch.	42	59	62	69	70	68	60	50	74
	Rad.	41	55	43	50	55	51	42	29	59
400L	Inlet	42	61	69	72	67	66	63	50	76
	Disch.	47	63	66	70	69	68	64	51	75
	Rad.	45	58	45	52	52	50	46	30	61

## Airflow Performance Characteristics

- Airflow in m<sup>3</sup>/hr & m<sup>3</sup>/s, static pressure in mmWG & Pa
- Dry air at 20°C and 760 mmHg.
- According to UNE 100-212-89, BS 848 Part 1, AMCA 210-85 & ASHRAE 51-1985.

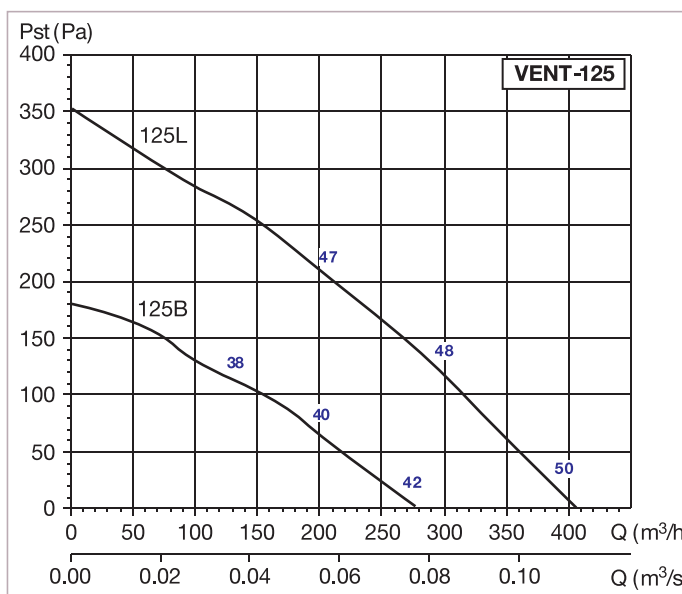
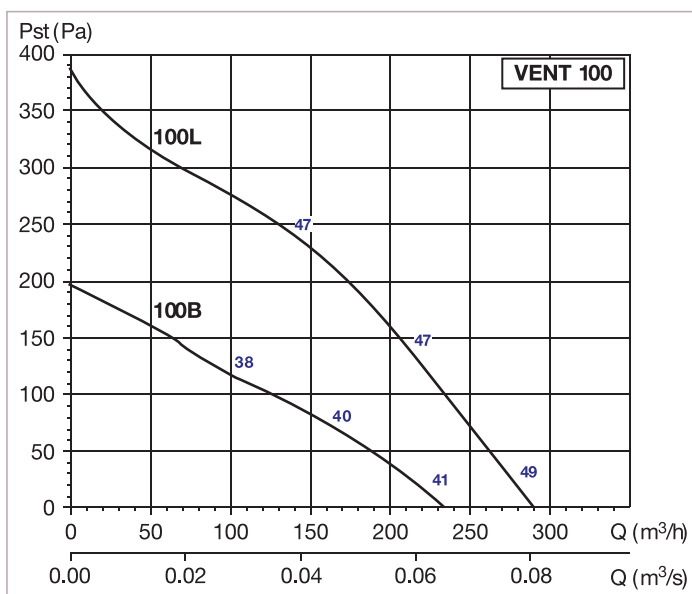

## Airflow Performance Characteristics

- Airflow in m<sup>3</sup>/hr & m<sup>3</sup>/s, static pressure in mmWG & Pa
- Dry air at 20°C and 760 mmHg.
- According to UNE 100-212-89, BS 848 Part 1, AMCA 210-85 & ASHRAE 51-1985.

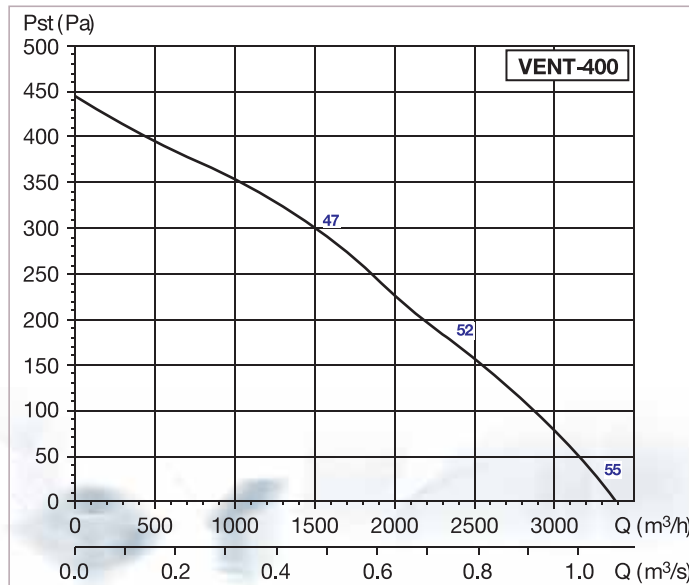
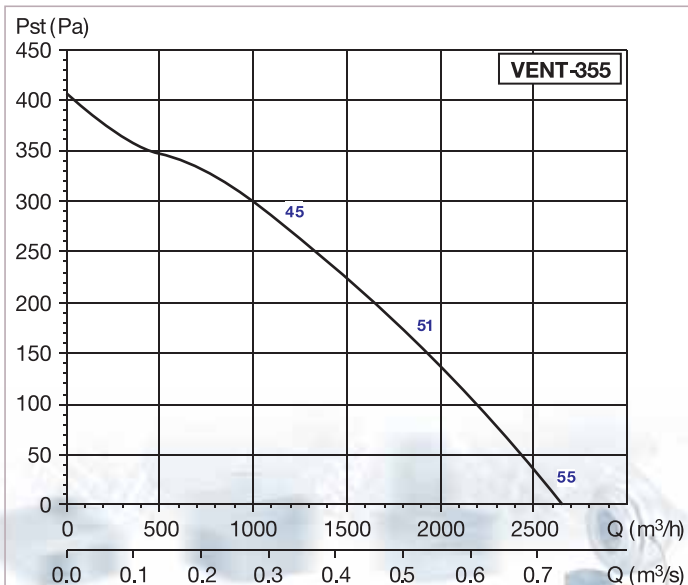
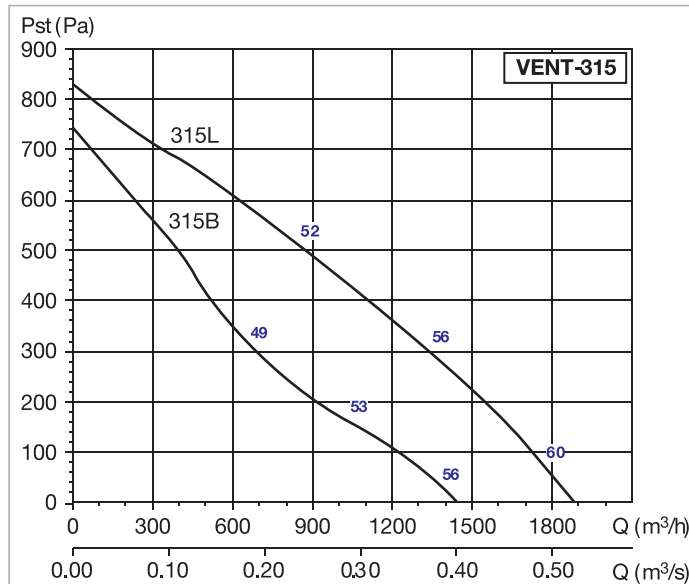
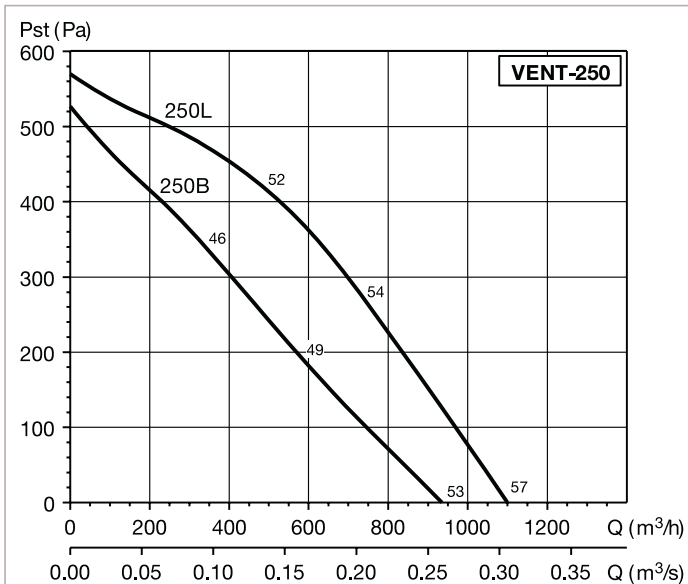
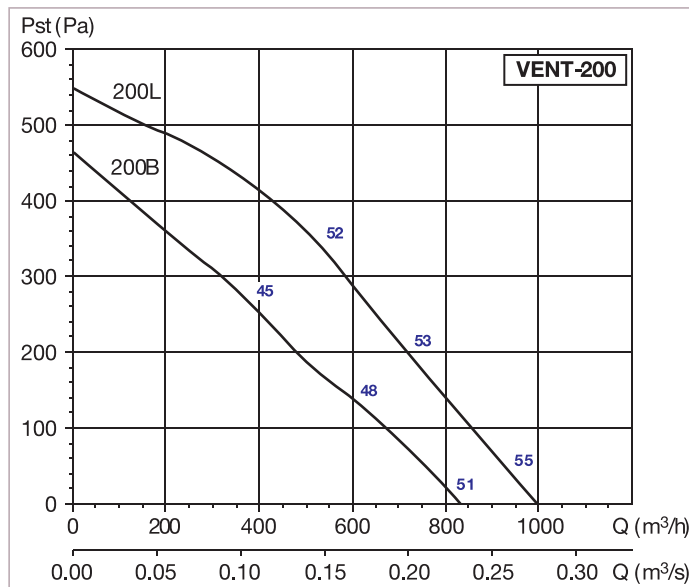
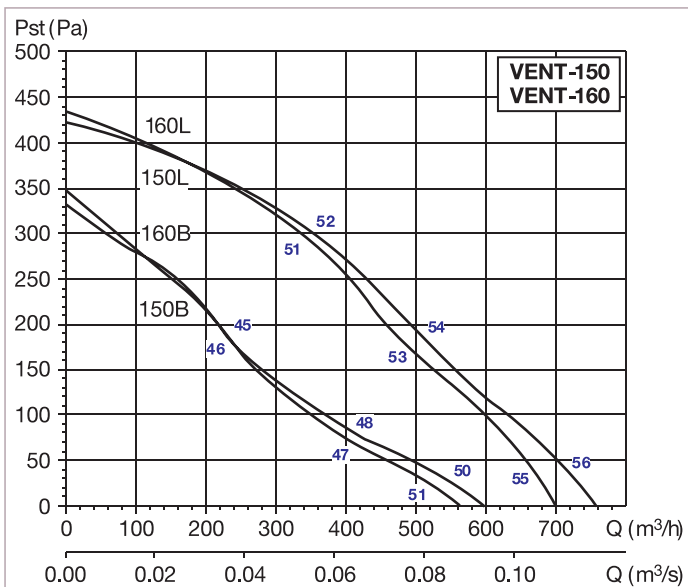

## ■ Electrical Accessories



Electronic single phase speed controllers  
REB



Autotransformer single phase speed controllers  
RMB



IP55 rated ON/OFF isolating switch



Electric heater battery controllers for 1Ph models up to 3600W and 3Ph models up to 6400W  
PULSER



Electric heater battery controllers for 3Ph models up to 16500W  
TTC-2000



Duct mounted temperature sensor  
TG-K330



Room wall mounted temperature sensor  
TG-R530  
TG-R430

## ■ Electric Heater Battery Configurations

Battery Type	Room temperature control	Duct temperature control
MBE-100/04B	PULSER	PULSER + TGK-330
MBE-125/12B	PULSER	PULSER + TGK-330
MBE-160/21B	PULSER	PULSER + TGK-330
MBE-200/50T	PULSER	PULSER + TGK-330
MBE-250/60T	PULSER	PULSER + TGK-330
MBE-315/90T	TTC-2000 + TGR430 / TG-R530	TTC-2000 + TGK-330
MBE-400/120T	TTC-2000 + TGR430 / TG-R530	TTC-2000 + TGK-330

## ■ Mounting Accessories



In-Line Filter Boxes  
MFL

Model	Length (mm)	Height (mm)	Width (mm)	Filter type	Load at 6 m/s (Pa)
MFL-100	196	200	200	EU3	90
MFL-125	196	200	200	EU3	90
MFL-160	196	220	200	EU3	90
MFL-200	202	243	244	EU3	90
MFL-250	206	293	294	EU3	90
MFL-315	206	342	343	EU3	90
MFL-355	254	447	448	EU3	90
MFL-400	254	447	448	EU3	90



## ■ Mounting Accessories



**Electric Heater Batteries**  
MBE

Model	Length (mm)	Power (W)	Voltage (V)	Minimum Airflow (m <sup>3</sup> /h)	Control type
MBE-100/04B	400	400	1/230	50	REG-6
MBE-125/12B	400	1200	1/230	70	REG-6
MBE-160/21B	400	2100	1/230	110	REG-6
MBE-200/50T	400	5000	2/400	170	REG-6
MBE-250/60T	400	6000	2/400	270	REG-6
MBE-315/90T	400	9000	3/400	420	TTC2000
MBE-400/120T	400	12000	3/400	690	TTC2000



**In-line Silencers**  
SIL

Model	Length (mm)	Ext Dia (mm)	Attenuation by frequency band (dB)							
			63	125	250	500	1K	2 K	4 K	8 K
SIL-125	600	224	2	5	13	21	37	37	31	9
SIL-160	600	280	2	9	14	23	25	16	11	6
SIL-200	600	315	2	8	11	23	25	17	9	4
SIL-250	600	355	2	6	10	19	25	16	7	3
SIL-315	900	500	2	2	3	9	21	8	4	6
SIL-355	900	560	4	4	7	13	14	3	8	7
SIL-400	900	600	2	3	4	10	14	6	0	6



**Mounting foot**  
(supplied with unit as standard)



**Flexible connectors**  
ACOP-VENT



**Protection Grille**  
DEF-VENT



**Aluminium flexible ducting**  
GSA

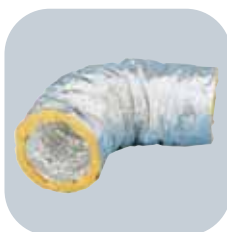

**Insulated aluminium ducting**  
GSI



**Worm drive duct connectors**  
CX



**Metal inlet valves**  
BOC



**Plastic inlet valves**  
BOR



**Circular inlet grilles**  
GCI



**Interior square grilles**  
GRI

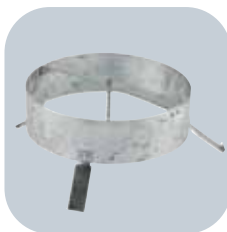

**GCI mounting frame**  
VR

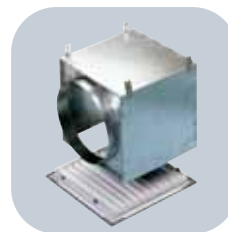

**GRI mounting frame**  
RP



**Backdraught shutters**  
CAR

